

SECTION A-A
SCALE 1:1

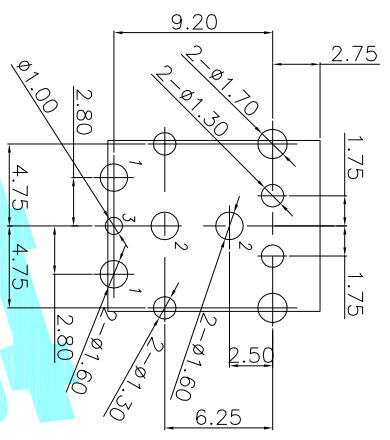

RECOMMENDED P.C.B LAYOUT
TOP VIEW (TOLERANCE: ±0.05)

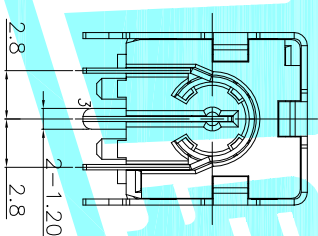
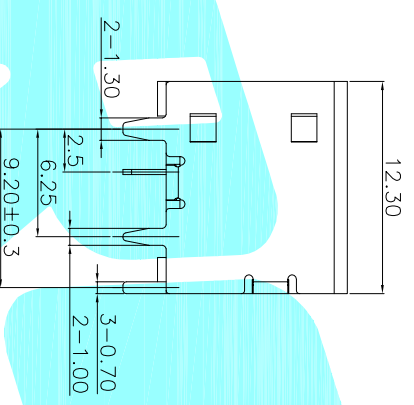
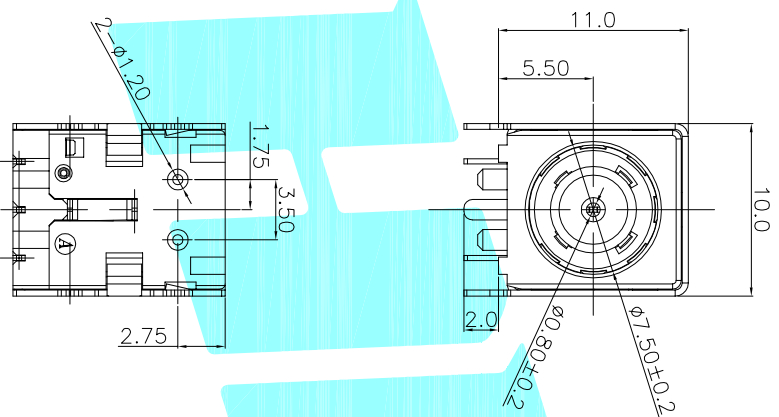

- SPECIFICATIONS:
- ELECTRICAL CHARACTERISTICS:
 - RATING: 42V 10A
 - CONTACT RESISTANCE: 30mΩ MAX (INITIAL)
 - DIELECTRIC WITHSTANDING VOLTAGE: 500V AC FOR ONE MINUTE.
 - INSULATION RESISTANCE: 100MΩ MIN. MEASURED BY 250 VDC.
 - MECHANICAL CHARACTERISTICS:
 - INSERTION FORCE : 3.0 KGF Max.
 - WITHDRAWAL FORCE : 0.35 KGF Min.
 - LIFE TEST: 5,000 CYCLES MIN.
 - TO CONFORM TO SINGATRON HAZARDOUS SUBSTANCE FREE SPEC.

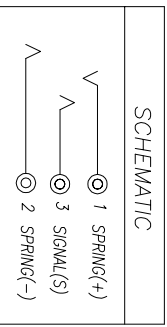

ITEM	PART NAME	TER.NO.	QTY.	MATERIAL	FINISHING	REMARK
③	Shell		1	SPCC	Plating Nickel	
②	Terminal		5	Phosphor bronze	Plating silver	
①	Housing		1	PBT	Black	

DRAWN J.X.Zhong 2018/05/15
 CHECKED
 APPROVALS
 TITLE: PHONE JACKES
 PART NO. DC-071
 SCALE: 1:1
 DRAWING NO. SHEET 1 OF 1

ECN NO.	REV.	DATE.	DESCRIPTION.	CHANGE.	CHECK.	APPRO.
	A		NEW			